

# **Applications Guide**

**For the integration of  
Glentek digital pulse-stepper servos  
with Sound Logic Breakout boards  
and Artsoft Mach series software**



Applications Guide  
Revision Date:  
29 Oct 2007



## TABLE OF CONTENTS

Table of Contents .....	3
Overview .....	4
Servo Motor Versus Stepper Motor.....	5
Selecting a Glentek Servo Motor to Replace a Stepper Motor .....	7
How to Choose the Correct Amplifier .....	8
Sound Logic Breakout Board .....	9
Artsoft Controls Software .....	10
Advantages of Using Glentek Microstepping Servo Amplifiers .....	11
Brushless Versus Brush-type Comparison .....	12



## Overview

This guide is designed to assist the customer with the integration of Glentek's Amplifiers and Motors to their systems, utilizing high response micro stepping servos instead of low resolution stepper motors. The difference between stepper motors and servo motors with high resolution encoders will be pointed out and examples will be given. Also an overview of Glentek servo motors and amplifiers will be provided. This guide will answer many questions that are asked when trying to retrofit an older machine with Position Loop stepper servos. The guide also explains how to choose the correct servo motor replacement for a stepper motor.

The guide describes how to set up the Glentek Position Loop Stepper servo amplifier and connect it to the Sound Logic breakout board. Also, we have included a brushless vs. brush type comparison for those of you that are currently using brush type motor in your servo system.

For additional information such as tuning the Glentek servo amplifier in pulse follower mode, go to the Glentek website at [www.Glentek.com](http://www.Glentek.com), and open the installation and operation manual (24Aug07) for Omega series amplifiers under "Support > Manual". To connect to Sound Logic Breakout board, see input schematic for pulse and direction position mode, page 15. Also, the tuning section for pulse and direction begins on page 41 of the manual.

## Servo Motor Versus Stepper Motor

Stepper motor versus servo motor is a question that has been asked by many people with projects where they could incorporate either motor. There are many benefits that the servo system has over the stepper system. Servo motors and servo amplifiers are designed to maximize efficiency between the motor and amplifier. This is done by commanding current only when the motor has to provide torque for the system. This is different than some stepper motors where they are commanding current continuously. This leads to poor efficiency as the usable energy that is commanded to the motor when it is not moving is dissipated into heat. Also, steppers have very poor torque characteristics at higher speeds.

When a stepper system utilizes microstepping up to 25,000 micro steps per revolution, it is important to note that since the stepper motor is open loop, it does not usually achieve the desired location, especially under load. Particularly poor positional accuracy will result when using microstepping, which is primarily utilized for smoothness of motion, not accuracy.

The servo motor has an encoder which keeps track of the movement of the shaft. The encoder is connected to an amplifier where the encoder information is used to determine degrees of rotation of the motor shaft. This number is then compared with the number that it was commanded to move. The difference then becomes an error signal to a high gain, high bandwidth digital servo loop within the servo amplifier. The error is always nulled to zero in steady state conditions. For this reason, you see the digital step servo never loses steps or position as a step motor can if it is inadvertently stalled and misses a step, thus losing position and requiring a re-homing cycle. A typical encoder is around 2500 lines of resolution. This allows for very precise movement. The number of lines on the encoder can be increased for better accuracy.

The typical stepper motor has a step size of 1.8 degrees. This is equivalent to having a 50 line encoder which is a very low resolution encoder. Encoders range from 1000 to 5000 lines per revolution. As an example, a 1000 line encoder would have 20 times better resolution than a 1.8 degree stepper.

$$1000 \text{ line encoder} = 4000 \text{ counts/revolution}$$

$$1.8^\circ = 200 \text{ counts/revolution}$$

The typical stepper servo system will have added efficiency as well as performing the job in a smooth quiet manner. The stepper servo system is a upgrade for the customer who is serious about having their system move in the most precise manner possible. If the precision needs to be greater it is possible to install a higher line encoder. Glentek typically installs 2500 line encoders on their Nema 23 size servo motors. A 2500 line encoder allows you to command a step of 1/10000th of a revolution. This provide excellent smoothness and accuracy and is very helpful for milling as well as precise movements.

## Application Guide

The Glentek Nema 34 and Nema 42 servo motors are supplied with 5000 line encoders. This high resolution (20,000 counts per revolution) provides a smoother higher bandwidth velocity loop for fine machining finishes.

To take full advantage of this high step resolution capability, the pulse data required from the Artsoft software would have to be as shown in the following example:

A milling machine with a 5 pitch ball screw traveling at 400 inches per minute would require the following calculated data rate:

$$\frac{400 \text{ in}}{\text{min}} \times \frac{1 \text{ rev}}{0.2 \text{ in}} \times \frac{20,000 \text{ pulses}}{1 \text{ rev}} \times \frac{1 \text{ min}}{60 \text{ sec}} = 666.7 \text{ KHz}$$

In this example, 1 pulse would equal 0.00001 inches of axis travel.

If you decide to have one pulse equal to 0.0001 inches of travel in the above example, the maximum data pulse rate would be 66.7 KHz.

It is our understanding that the Sound Logic Breakout board is currently being updated to operate with the USB port of a standard computer and this will allow higher data transfer rates.

Glentek servo motors and servo amplifiers provide the highest quality and reliability as well as being reasonably priced.

## Selecting a Glentek Servo Motor to Replace a Stepper Motor

This section provides the specifications of various stepper motors so they can be compared to equivalent servo motors. This should help in clearing up some of the confusion involved in choosing a servo motor to replace a stepper.

Both Servo and Stepper motors have peak and continuous torque ratings. You will notice that the peak and continuous torque ratings are generally the same with the stepper motor. Whereas, in a servo motor, the peak torque rating is generally two or three times higher than the continuous torque rating.

To select a servo motor, the peak torque must be equal to or greater than the peak torque rating of the step motor. Since the horse power to weight ratio of a stepper motor is similar to that of a servo motor, you should start out by selecting a servo motor approximately the same weight as the stepper motor.

As a final system test, after selecting the Glentek servo motor replacement for your stepper motor, Glentek strongly recommends you to install the servo motor and exercise your machine at maximum axis duty cycle to make sure that the servo motor runs without over heating and the following error remains within desired specification.

Frame Size	Stepper Motor		Glentek Servo Motor				
	Torque (in-oz)	Weight (lbs)	Model Number	Peak Torque (in-oz)	Cont. Torque (in-oz)	Weight (lbs)	Overall Length (inches)
NEMA 23	156	1.5	GMBN2310	216	72	2.3	4.59
NEMA 23	185	1.5					
NEMA 23	282	2.2	GMBN2320	588	168	3.8	6.12
NEMA 23	425	3.1					
NEMA 23	495	3.1					
NEMA 34	400	3.7	GMBN3420	850	298	9.0	6.89
NEMA 34	465	3.7					
NEMA 34	640	5.3					
NEMA 34	906	5.1	GMBN3430	1186	395	12.0	7.88
NEMA 34	1160	8.8					
NEMA 34	1200	8.4					
NEMA 34	1810	12.3					
NEMA 42	1869	16.53	GMBN4230	1274	424	15.0	6.42
NEMA 42	2830	19.8	GMBN4260	2547	848	21.0	8.78

in-lb = in-oz x 0.0625

N-m = in-oz x 0.007

## How to Choose the Correct Amplifier

Glentek produces a wide range of amplifiers. Some amplifiers have built in DC power supplies, referred to as “Stand Alone”, while others are referred to as a module that requires customers to furnish DC power supply. Glentek also offers 2 and 4 axis packages with power supply for multi-axis systems.

If the applications requires a NEMA 23, 34 or 42 motor, Glentek recommends using the SMB/SMC 9715 or SMB/SMC 9808 amplifiers. The SMB/SMC 9715 is a DC module amplifier primarily used for multi axis systems. If it becomes necessary, the digital servo amplifiers can be configured to run either brushless or brush type motors. However, Glentek does not recommend using a brush type motor if it is possible. For more information on Glentek amplifiers, refer to installation and operation manual (24AUG07) at the Glentek website.

The SMB amplifier has buss derived logic power, which means that you only need to provide buss power to the amplifier to operate the digital logic board. However, in case of buss power removal or failure, the digital logic board would not be able to keep track of the position of the motor shaft, and any fault data would be lost. For this reason, the SMC amplifiers have an external “Keep Alive” logic power source. This source can either be 5VDC, 24VDC or 110VAC depending on the model. Again, having the “Keep Alive” power source allows the amplifier to keep track of all the digital data. Since the data is not lost, the customers would not have to restart the machine at the “home” position i.e. if a machine happened to lose buss power in the middle of a job once buss power was restored it would allow the amplifier to continue and finish the job.

For detail model numbering, please refer to our installation and operation manual (24Aug07), pages 69-85.

## Sound Logic Breakout Board

The Sound Logic breakout board can be used with a Glentek motor and drive combination. The Sound Logic board enables a customer to use their computer to send pulses to this board. This board then sends these pulse and direction signals to the amplifier. The board connects directly to the parallel printer port on a standard computer. In the future, the breakout board will be able to be controlled by the standard USB port as well as the parallel printer port. The USB port will allow higher frequency bandwidth pulse and direction signals to be ported out to the microstepping servo drives.

The board that was tested at Glentek is the Sound Logic PC-2-Route Rev. 1.9

For more information, please refer to Bob Campbell with Campbell Designs.  
<http://www.campbelldesigns.com/>

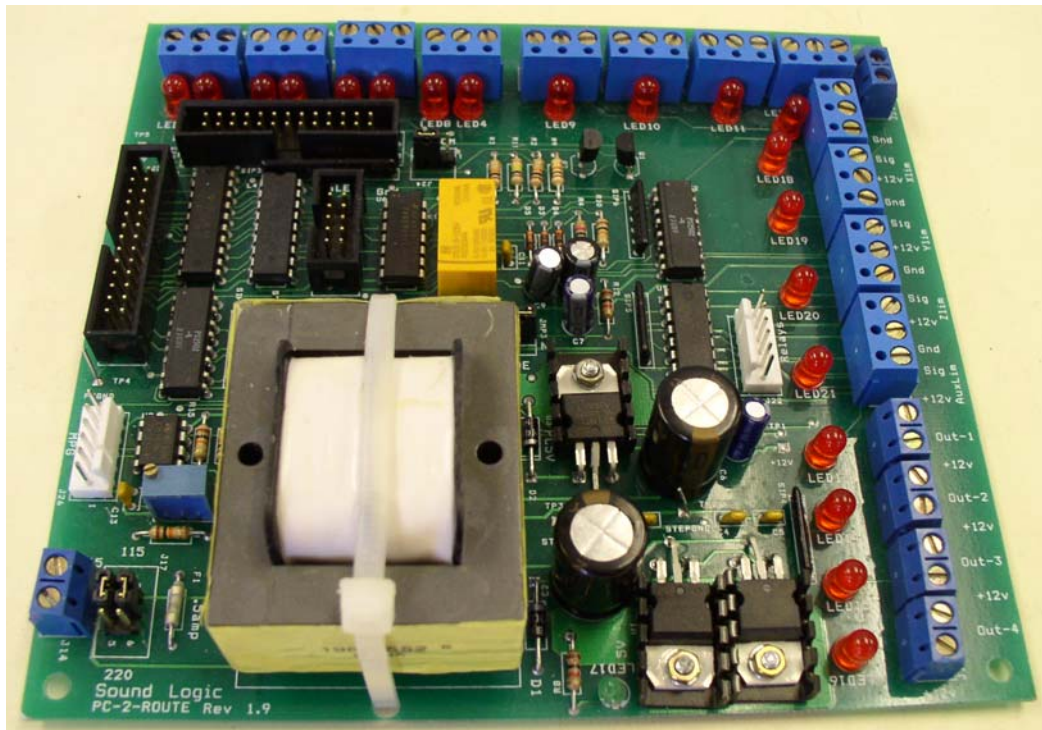

## Artsoft Controls Software

Artsoft Controls software enables a computer to turn a manual milling machine into a computer controlled machine. This software was used in conjunction with the Sound Logic breakout board to effectively evaluate the needs of the CNC community. This software is complex for the novice user. However, Artsoft has many forums where help can be found and Artsoft also offers phone technical service. Artsoft also has the ability to use their Mach software as a basis and create a program that is used specifically for an application.

This software offers many command functions for the CNC machining process. The software is able to control many characteristics for the pulses that are sent to the breakout board.

For more information refer to the Artsoft Controls website.  
<http://www.artsoftcontrols.com/>

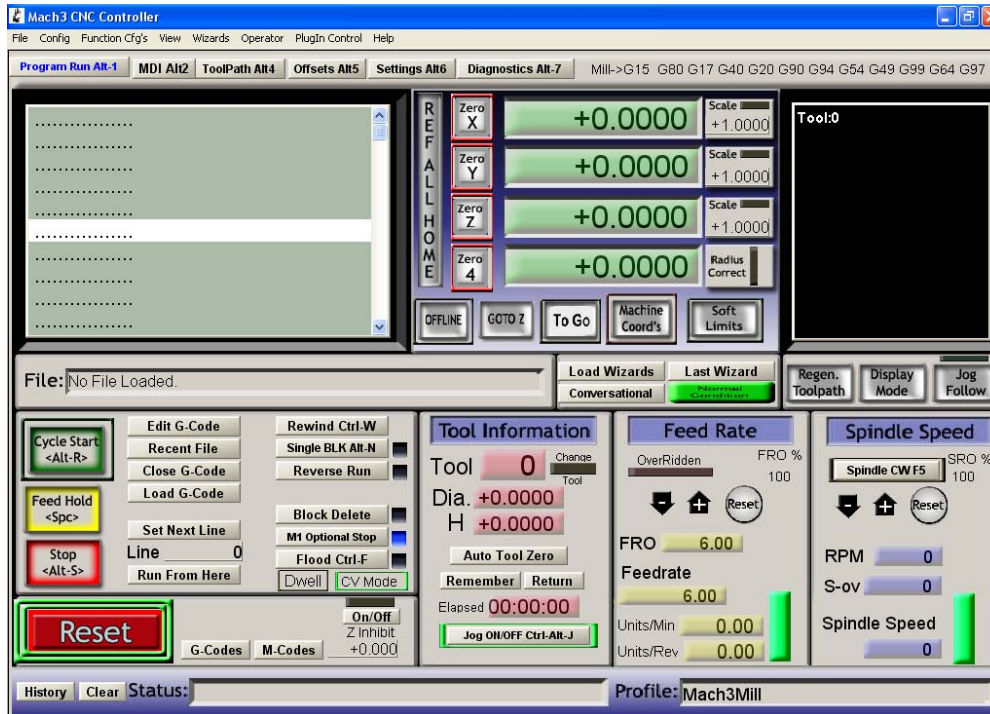

## **Advantages of using Glentek Microstepping Servo Amplifiers**

Glentek Omega series digital PWM servo amplifiers offer the latest in high performance DSP control of both brushless and brush type motors. With extensive utilization of surface mount technology and special heat transfer techniques, the Omega series offers one of the world's most powerful products for a given form factor.

Following are some of key features of Glentek high performance servo amplifiers:

1. Digitally tuned - All parameters set digitally. No potentiometers to adjust. DSP control for the ultimate in system performance.
2. Silent operation - 24KHz PWM standard.
3. Smooth operation - The Glentek digital amplifier generates, using a Taylor expansion, a sinewave output to the brushless servo motors, matching the back EMF waveform of the motor exactly. This eliminates cogging and ripple torque and provides for extremely smooth operation.
4. Wide operating voltage - 20-370VDC for amplifier modules. 110-130VAC or 208-240VAC for Stand Alone.
5. Direct AC operation - No transformer required for stand-alone unit or multi-axis chassis. The power supply section includes DC power supply, cooling fan(s), soft-start circuitry and a regenerative voltage clamp with dumping (shunt) resistor
6. RS232 - high speed (115.2K baud) serial communication interface for set-up and tuning.
7. Software configurable - Glentek's Windows™ based MotionMaestro™ software provides ease of set-up and tuning with no previous programming experience required.
8. Dedicated digital inputs - Fault, +/- limits, motor over temperature and reset.
9. Fault protection - Amplifier RMS over current, amplifier under/over voltage, amplifier over temperature, motor over temperature and amplifier output short circuit. See installation and operation manual (24Aug07), page 24 (Faults).
10. Current Monitoring - View axis current while axis is moving at a fixed command rate. This is very useful in machine maintenance. As an example, if something is binding the axis, the running current will go up. This torque monitoring is not available in stepper systems. See installation and operation manual (24Aug07), page 23 (Setup Oscilloscope). Select trace attributes source for "Current Measured".
11. Low Speed settable electronic circuit breaker with foldback current settings. See installation and operation manual (24Aug07), page 20 (Motor Safety).

### **Conclusion**

In general summary, comparing a stepper motor system with a servo motor system utilizing a Glentek high bandwidth digital servo amplifier in the microstepping mode is like comparing a Model "T" Ford with a Porsche or Ferrari sports car in performance capabilities.

## Brushless versus Brush-type Comparison

There are two basic types of motor design that are used for high-performance motion control systems: Brush-Type PM (permanent magnet), and Brushless-Type PM. As you can see in the figure, a brush-type motor has windings on the rotor (shaft) and magnets in the stator (frame). In a brushless-type motor, the magnets are on the rotor and the windings are in the stator.

To produce optimal torque in a motor, it is necessary to direct the flow of current to the appropriate windings with respect to the magnetic fields of the permanent magnets. In a Brush-Type motor, this is accomplished by using a commutator and brushes. The brushes, which are mounted in the stator, are connected to the motor wires, and the commutator contacts, which are mounted on the rotor, are connected to the windings. As the rotor turns, the brushes switch the current flow to the windings which are optimally oriented with respect to the magnetic field, which in turn produces maximum torque.

In a brushless motor there is no commutator to direct the current flow through the windings. Instead, an encoder, hall sensors or a resolver on the motor shaft senses the rotor position ( and thus the magnet orientation). The position data is fed to the amplifier which in turn commutates the motor electronically by directing the current through the appropriate windings to produce maximum torque. The effect is analogous to a string of sequencing Christmas lights: the lights seem to chase each other around the string. In this case, the magnets on rotor "chase" the magnetic fields of the windings as the fields "move" around the stator.

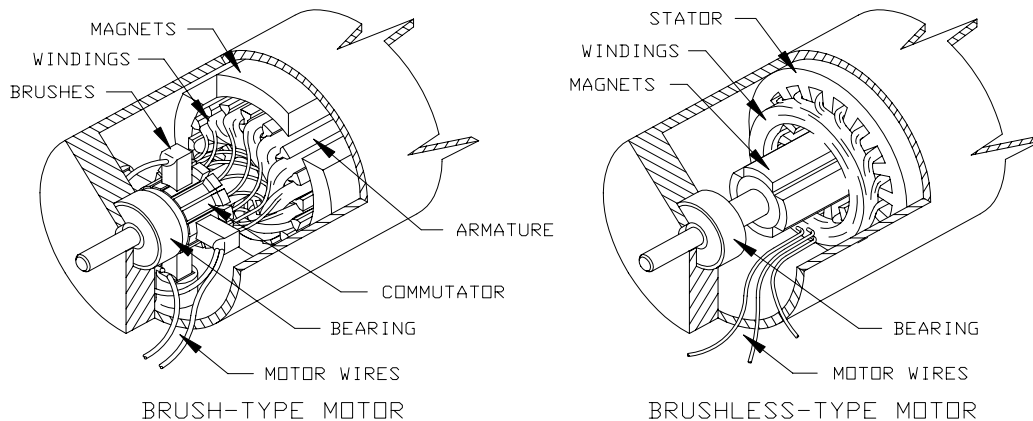

The brushless motors are more reliable as Brush maintenance is eliminated and no brush dust is generated. The brushless motor can be driven to much higher RPM limits and typically have lower inertia. The brushless motor also dissipates heat more efficiently since the stator windings are thermally connected to the outside of the motor case. It is also safer for explosive atmospheres and quieter and less electrical noise generated as there is no brush arcing in a brushless motor.



## **Omega Series Digital PWM Brushless Servo Amplifiers**

- PWM (Pulse-Width-Modulated) Brushless servo amplifiers to 20KW

## **Analog Brush Type Servo Amplifiers**

- Linear Brush type servo amplifiers to 2.6KW
- PWM (Pulse-Width-Modulated) Brush type servo amplifiers to 28KW

## **Analog Brushless Servo Amplifiers**

- Linear Brushless servo amplifiers to 3.5KW
- PWM (Pulse-Width-Modulated) Brushless servo amplifiers to 51KW

## **Permanent Magnet DC Brush Type Servo Motors**

- Continuous Torques to 335 in. lb.
- Peak Torques to 2100 in. lb.

## **Permanent Magnet DC Brushless Servo Motors**

- Continuous Torques to 1100 in. lb.
- Peak Torques to 2200 in. lb.



**GLENTEK**

*"Solutions for Motion Control"*

Applications Guide  
Revision Date:  
29 Oct 2007

208 Standard Street, El Segundo, California 90245, USA.  
Telephone: (310) 322-3026; Fax: (310) 322-7709  
www.glentek.com e-mail sales@glentek.com