

ANALOG BRUSH PWM SERVO AMPLIFIERS SMA7110 MULTI AXIS AMPLIFIER MODEL NUMBERING

ANALOG BRUSH PWM SERVO AMPLIFIERS SMA7110 AMPLIFIER MODEL NUMBERING

This section explains the model numbering system for Glentek's SMA7110 Analog Brush PWM servo amplifier. The model numbering system is designed so that you, our customer, will be able to quickly and accurately create the model number for the amplifier that best suits your needs. In order to accurately select a complete part number, please choose the industry standard mounting configuration which meets your needs (i.e. Module or Multi Axis) and then complete the amplifier configuration code per your requirements.

Note: A complete model number example follows each section and includes a full description of the individual codes which make up the complete model number.

Multi Axis Model Numbering

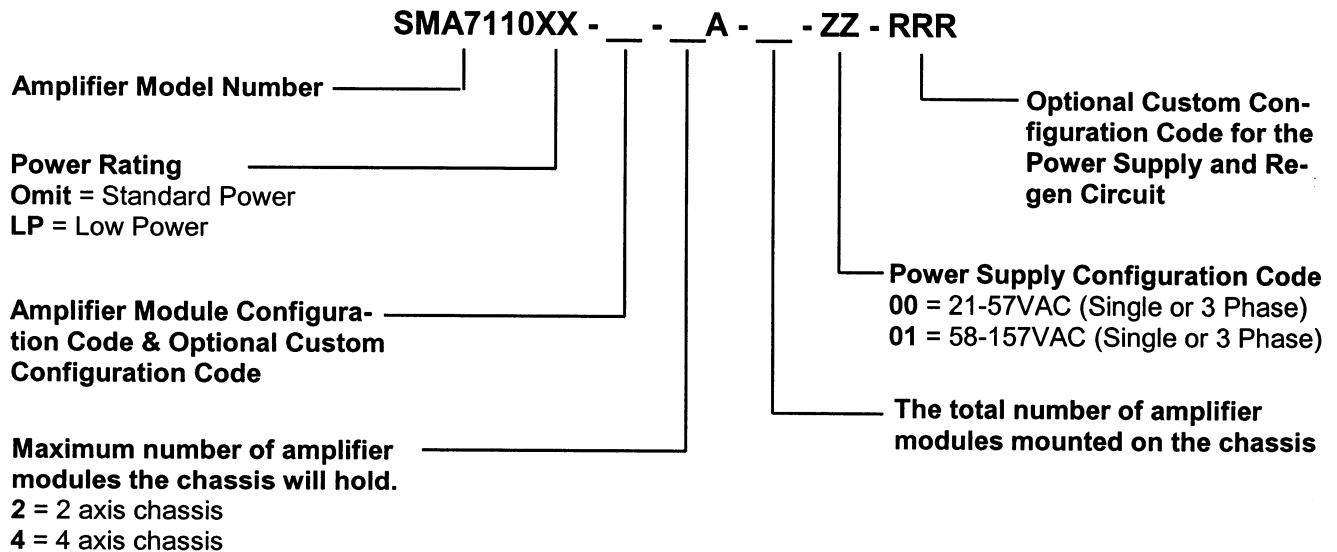

Example: SMA7110 - 00F - 4A - 3 - 01

Type A Reset, type A Inhibit, type A Limits,
Differential signal input, Current mode,
+5VDC Logic, 80-220VDC Operation of module.

58-157VAC operation
3 amplifier modules installed
4 axis chassis w/power supply

ANALOG BRUSH PWM SERVO AMPLIFIERS

SMA7110 MULTI AXIS AMPLIFIER MODEL NUMBERING

LOGIC INPUT CONFIGURATION DESCRIPTION:

There are four logic inputs: Limit+, Limit-, Inhibit and Reset In. They may be configured for active-high or active-low signals and pull-up or pull-down termination (type A, B, C and D). All logic inputs have a 0 to +5VDC range. Following is a description of the various types (A, B, C and D) and how they apply to the inhibit input:

Type "A": Requires grounding of input to disable the amplifier (pull-up, active-low).

Type "B": Requires a positive voltage at input to disable the amplifier (pull-down, active-high).

Type "C": Requires grounding of input to enable the amplifier (pull-up, active-high).

Type "D": Requires a positive voltage at input to enable the amplifier (pull-down, active-low).

Amplifier Configuration Code

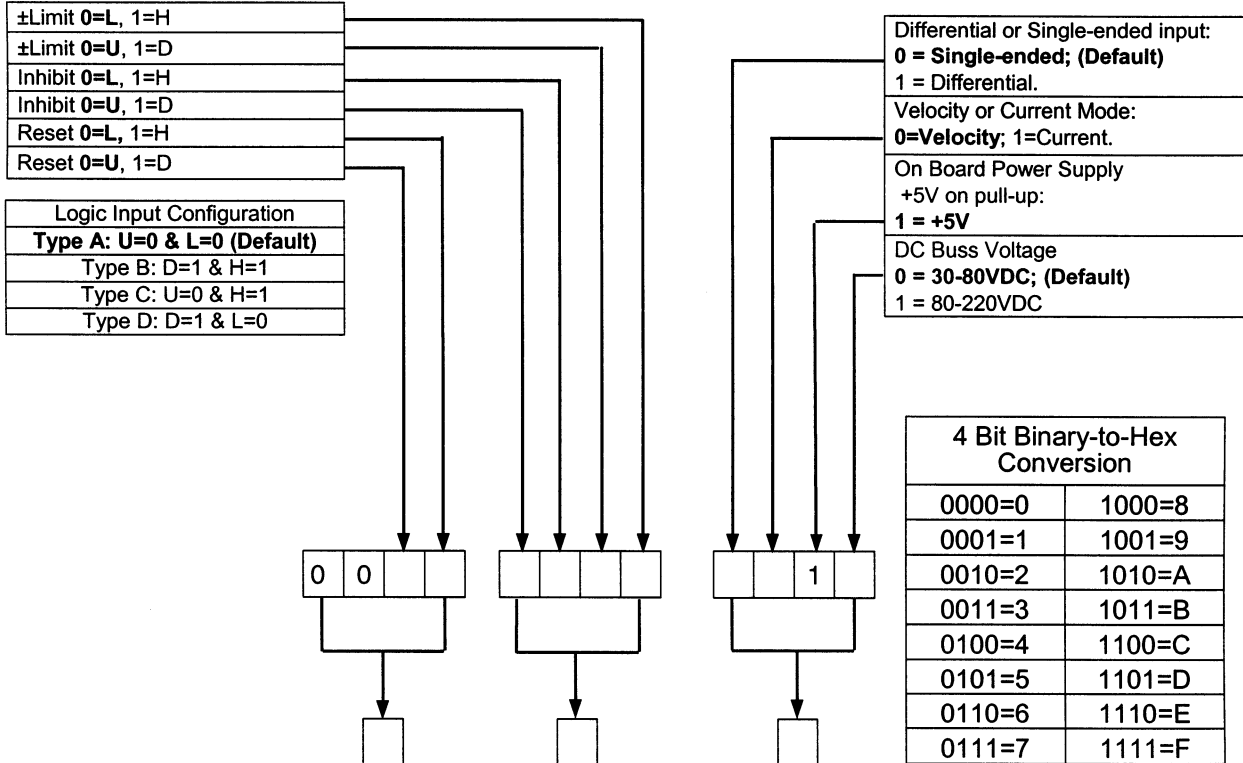

Example: SMA7110 - 04B - 1

Type A Reset, type C Inhibit, type A Limits,
Differential signal input, Velocity mode,
+5VDC Logic, 80-220VDC Operation.

Single amplifier module