

GLENTEK DC BRUSH SERVO MOTORS GMR4900 SERIES

Revision: 3/24/2017



Glentek's GMR4900 series of high performance, permanent magnet DC brush servo motors utilize high-energy Neodymium-Iron- Boron (NdFeB) magnets, which provide more torque in a smaller package with higher dynamic performance than traditional ferrite magnet designs. In addition, due to high torque to inertia ratio of these motors, they are ideal for applications which require high acceleration and deceleration characteristics or where the physical size of the motor is a major concern.

- Continuous Torque Range:
19.0 Lb-in (2.15 Nm) to 65.0 Lb-in (7.34 Nm)
- Peak Torque Range:
95.0 Lb-in (10.75 Nm) to 325.0 Lb-in (36.70 Nm)

GMR4900 SERIES FEATURES

High-energy Neodymium-Iron-Boron (NdFeB) magnet design provides more torque in a smaller package with higher dynamic performance.

Skewed armature design provides ultra smooth operation (i.e. low cogging torque) at all speeds.

Various electrical windings are available as standard to suit both low and high voltage amplifiers in order to provide optimum speed and torque characteristics. Optional custom electrical windings are available to meet virtually any requirement.

Worldwide standard mounting configurations are available (Square, Round, NEMA 42, and NEMA 56C).
Optional custom mounting configurations are available to meet virtually any requirement.

Industry standard lead termination configurations. (i.e. MS connectors, fluid tight strain relief cable exit, NPT hole with flying leads and terminal boxes)

Optional industry standard feedback devices. (i.e. high performance silver commutator tachometers, and encoders)

Class H insulation standard.

Standard operating temperature is dependent on the feedback device installed. Motors with resolver feedback can be specially configured to operate down to -40°C.

Optional 24VDC holding brakes are available.

Optional IP65 sealing is available

RoHS compliant.

CE marked.

UL Recognized Component for US and Canada.

GMR4900 SERIES ENVIRONMENTAL CONDITIONS

Storage Temperature: -20°C to 70°C

Operating Temperature: Standard: -20°C to 40°C without derating, derate torque 10% per 10°C above 40°C
Special: -40°C to 40°C without derating, derate torque 10% per 10°C above 40°C

Humidity: 5% to 95% relative humidity, non-condensing

Altitude: Up to 1000m without derating, derate torque 10% per 1000m above 1000m

GMR4900 SERIES SELECTION TABLE

K_T = Torque Constant • K_V = B_{EMF} = Volts/1000 RPM • L_A = Inductance

Model Number	Power @ Max Speed		Cont. Stall Rating			Peak Stall Rating			K_T		R_A	L_A	RPM	K_V	Armature Inertia	
	HP	KW	Lb-in	Nm	Amps	Lb-in	Nm	Amps	Lb-in/A	Nm/A	Ω	mH	Max	V/Krpm	Lb-in-sec ²	Kg-m ²
GMR4910-26	1.21	0.903	19	2.15	8.6	95.0	10.75	43.0	2.22	0.25	0.8	2.30	4000	26	0.00600	0.000678
GMR4910-37	1.12	0.835	19	2.15	5.9	95.0	10.75	29.5	3.20	0.36	1.4	4.29	3700	37	0.00600	0.000678
GMR4920-38	2.06	1.537	35	3.95	10.8	175.0	19.75	54.0	3.23	0.36	0.5	1.49	3700	38	0.00900	0.001017
GMR4920-68	1.17	0.873	35	3.95	6.0	175.0	19.75	30.0	5.80	0.66	1.9	5.26	2100	68	0.00900	0.001017
GMR4940-38	3.02	2.253	50	5.65	15.2	250.0	28.25	76.0	3.28	0.37	0.3	1.00	3800	38	0.01500	0.001695
GMR4940-78	1.34	0.999	50	5.65	6.6	250.0	28.25	33.0	6.60	0.75	2.2	10.80	1700	78	0.01500	0.001695
GMR4950-35	4.13	3.081	65	7.34	21.4	325.0	36.70	107.0	3.04	0.34	0.2	0.65	4000	35	0.01600	0.001808
GMR4950-57	2.58	1.924	65	7.34	13.4	325.0	36.70	67.0	4.87	0.55	0.6	1.64	2500	57	0.01600	0.001808

NOTE: All ratings based on a 40°C ambient temperature with the motor face mounted to a 12" x 12" x 1/2" aluminum heatsink.

BRAKE OPTION

Brake requires 24V DC input voltage. The values for "Extension" represent the nominal maximum length that the brake will add to the motor. For some models, the extension will be less. Please contact one of our sales engineers for the exact values.

Extension	Torque		Power
in. (mm)	Lb-in	Nm	Watts
2.19 (56)	159	18	24

GMR4900 SERIES DIMENSIONS

C1 = Bare Motor, C2 = Motor with Tachometer or Encoder, C3 = Motor with Tachometer and Encoder.
 Note: Dimensions are in inches (mm)

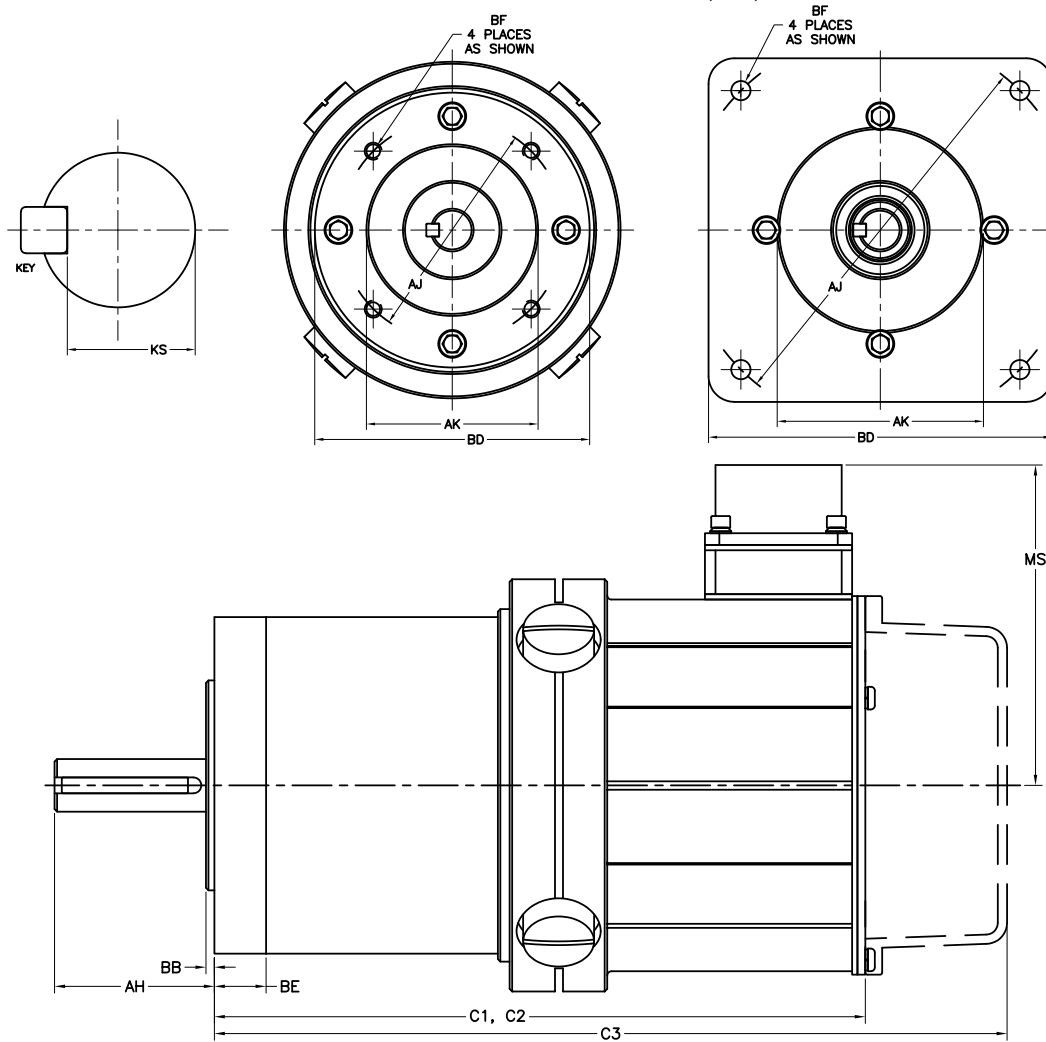

Model Number	Lbs (kg)	C1		C2		C3		P
		RND	SQR	RND	SQR	RND	SQR	
GMR4910	18.0 (8.2)	8.10 (205.7)		8.10 (205.7)		11.28 (286.5)		4.90 (124.46)
GMR4920	23.0 (10.5)	9.20 (233.7)		9.20 (233.7)		12.38 (314.5)		4.90 (124.46)
GMR4940	28.0 (12.7)	11.60 (294.6)		11.60 (294.6)		14.78 (375.4)		4.90 (124.46)
GMR4950	32.0 (14.5)	12.60 (320.0)		12.60 (320.0)		15.78 (400.8)		4.90 (124.46)

Connectors	MS
16-Pin	4.49 (114.0)
Liquid Tight	3.28 (83.31)
Terminal Box	5.54 (140.7)

Flange Type	Shaft				Flange/Face				Mounting Hole		
	AH	U (MAX)	KEY	KS	AJ	AK	BB	BD	BE (MAX)	BF Dia.	Tap
Round	1.90 (48.26)	0.6250 (15.88)	0.188 SQ. X 1.50	0.507- 0.517	3.500 (82.55)	2.498 (63.45)	0.10 (2.54)	4.00 (101.60)	0.62 (15.7)	-	1/4-20 ▽.50
Square M1	1.90 (48.26)	0.6250 (15.88)	0.188 SQ. X 1.50	0.507- 0.517	4.950 (125.73)	2.187 (55.55)	0.06 (1.52)	4.25 (107.95)	0.44 (11.18)	0.281 (7.14)	THRU
Square M2	1.90 (48.26)	0.6250 (15.88)	0.188 SQ. X 1.50	0.507- 0.517	5.741 (145.82)	3.000 (76.20)	0.10 (2.54)	5.00 (127.00)	0.44 (11.18)	0.281 (7.14)	THRU
Square M3	1.90 (48.26)	0.6250 (15.88)	0.188 SQ. X 1.50	0.507- 0.517	5.875 (149.23)	4.500 (114.30)	0.10 (2.54)	5.00 (127.00)	0.44 (11.18)	-	3/8-16 THRU
NEMA 42	1.32 (33.5)	0.6250 (15.88)	0.188 SQ. X 1.50	0.507- 0.517	4.950 (125.73)	2.187 (55.55)	0.06 (1.52)	4.25 (107.95)	0.48 (12.19)	0.281 (7.14)	THRU
NEMA 56C	2.06 (52.32)	0.6250 (15.88)	0.188 SQ. X 1.50	0.507- 0.517	5.875 (149.23)	4.500 (114.30)	0.09 (2.29)	6.50 (165.10)	0.44 (11.18)	-	3/8-16 THRU

CONNECTORS & PIN-OUT INFORMATION

With a positive voltage applied to the red motor lead (Motor +) with respect to the black motor lead (Motor -), the motor drive shaft will turn in the **counter-clockwise** direction as viewed from the shaft end.

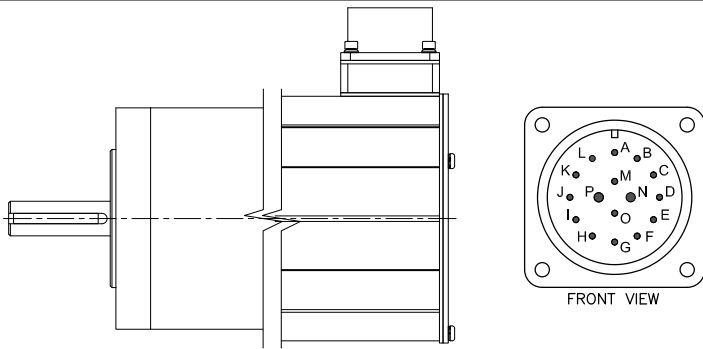
GMR 4900 Series Standard 16-pin MS Connector Location	MS3102R-24-07P 16-Pin	Encoder Feedback Function	Resolver Feedback Function
 <p style="font-size: small; margin-top: 10px;"> •Straight Mating Connector: MS3106F-20-27S •90° Mating Connector: MS3108E-20-27S </p>	A	Channel A+	Sine Sig (S1)
	B	Channel A-	Sine Com (S2)
	C	Channel B+	Cosine Sig (S3)
	D	Channel B-	Cosine Com (S4)
	E	Channel Z+	Reference Sig (R1)
	F	Channel Z-	Reference Com (R2)
	G	+5 VDC	N/C
	H	Common	N/C
	I	Cable Shield	N/C
	J	Tachometer +	
	K	Tachometer -	
	L	Tachometer Cable Shield	
	M	Brake +	
	N	Motor +	
	O	Brake -	
	P	Motor -	

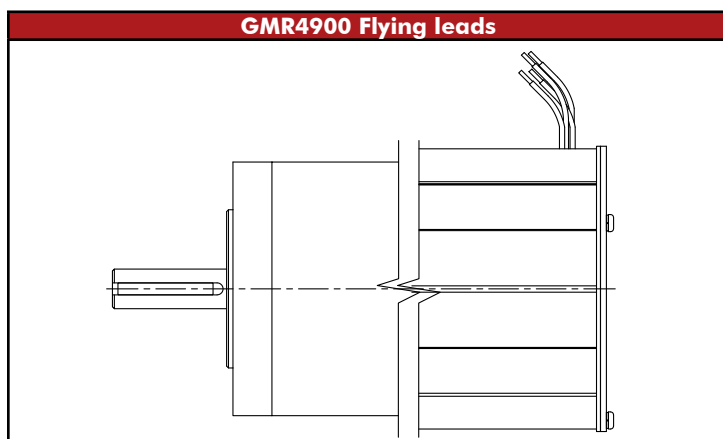
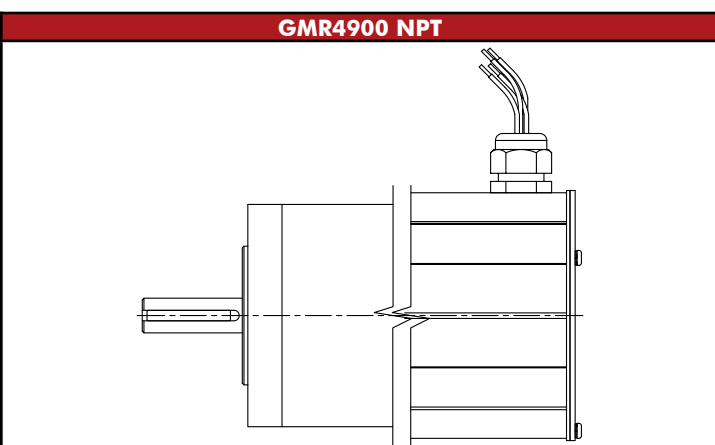
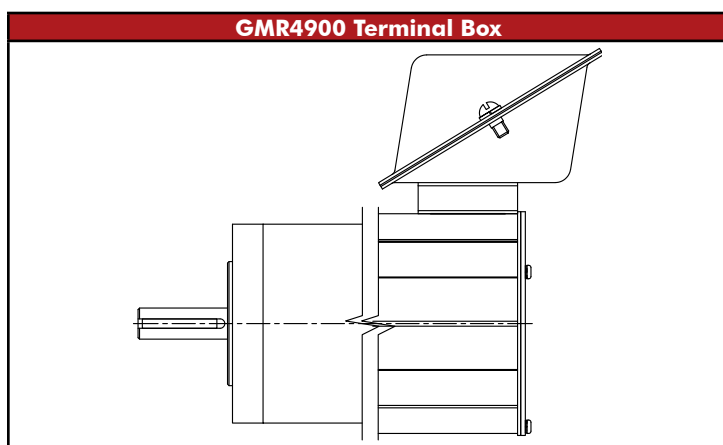

Glentek's GMR4900 Series offer Special mounting options please contact a Gletnek Sales Engineer for detailed information.

GMR4910-26 PERFORMANCE DATA

GMR4910-26

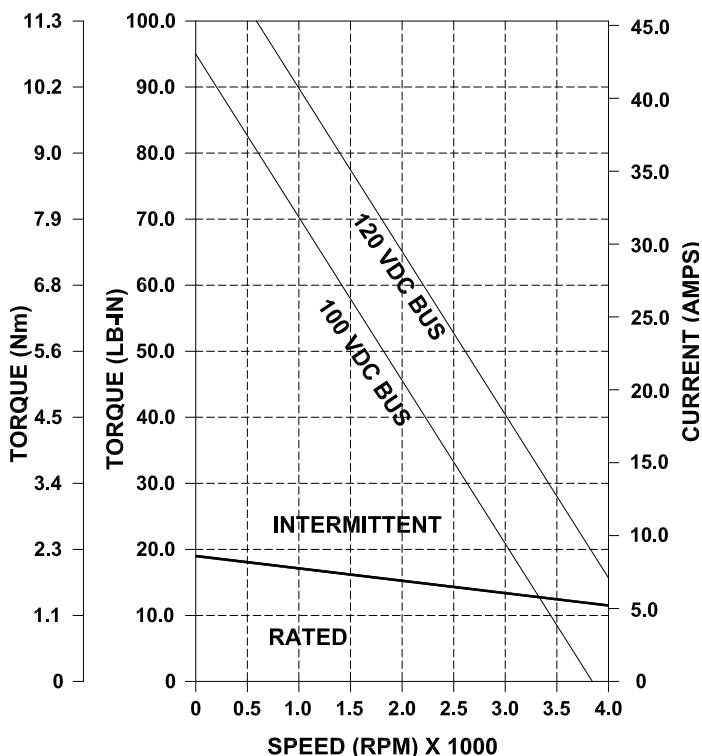

Power @ Max Speed	HP	1.21
	KW	0.903
Cont. Stall Rating	Lb-in	19
	Nm	2.15
	Amps	8.6
Peak Stall Rating	Lb-in	95.0
	Nm	10.75
	Amps	43.0
Torque Constant	Lb-in/A	2.22
	Nm/A	0.25
Resistance	Ohms	0.8
Inductance	mH	2.30
Maximum Speed	RPM	4000
Back EMF	V/Krpm	26
Armature Inertia	Lb-in-sec²	0.00600
	Kg-m²	0.000678

GMR4910-37 PERFORMANCE DATA

GMR4910-37

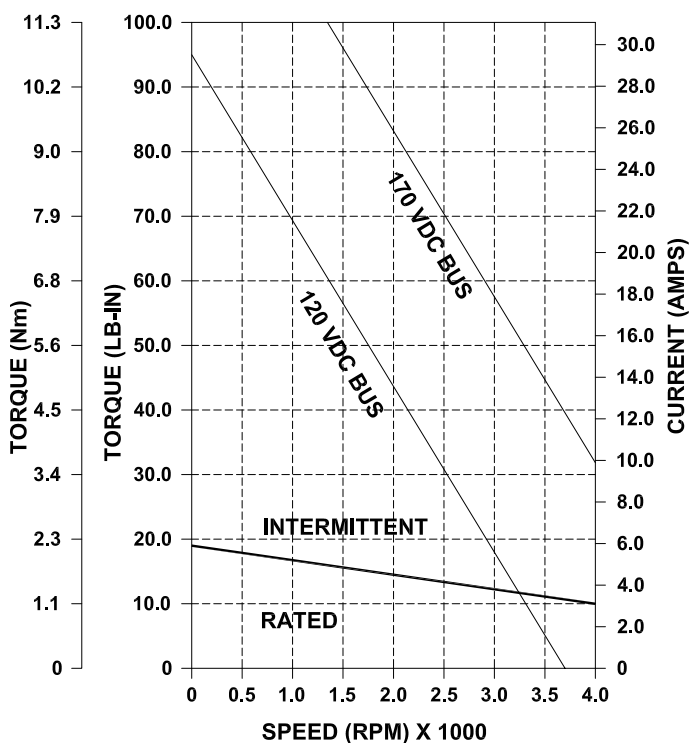

Power @ Max Speed	HP	1.12
	KW	0.835
Cont. Stall Rating	Lb-in	19
	Nm	2.15
	Amps	5.9
Peak Stall Rating	Lb-in	95.0
	Nm	10.75
	Amps	29.5
Torque Constant	Lb-in/A	3.20
	Nm/A	0.36
Resistance	Ohms	1.4
Inductance	mH	4.29
Maximum Speed	RPM	3700
Back EMF	V/Krpm	37
Armature Inertia	Lb-in-sec²	0.00600
	Kg-m²	0.000678

NOTE: All ratings based on a 40°C ambient temperature with the motor face mounted to a 12" x 12" x 1/2" aluminum heatsink.

GMR4920-38 PERFORMANCE DATA

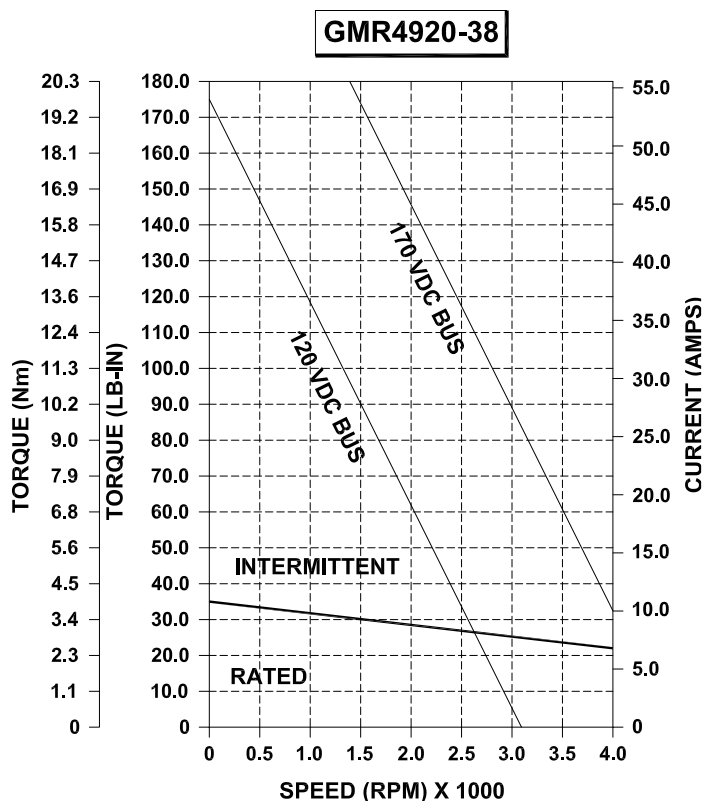

Power @ Max Speed	HP	2.06
	KW	1.537
Cont. Stall Rating	Lb-in	35
	Nm	3.95
	Amps	10.8
Peak Stall Rating	Lb-in	175.0
	Nm	19.75
	Amps	54.0
Torque Constant	Lb-in/A	3.23
	Nm/A	0.36
Resistance	Ohms	0.5
Inductance	mH	1.49
Maximum Speed	RPM	3700
Back EMF	V/Krpm	38
Armature Inertia	Lb-in-sec²	0.00900
	Kg-m²	0.001017

GMR4920-68 PERFORMANCE DATA

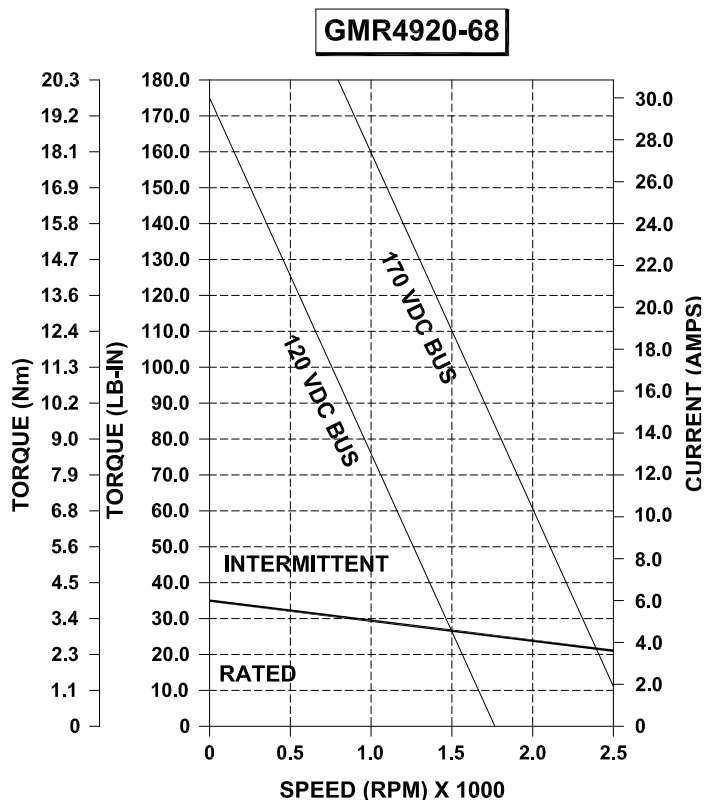

Power @ Max Speed	HP	1.17
	KW	0.873
Cont. Stall Rating	Lb-in	35
	Nm	3.95
	Amps	6.0
Peak Stall Rating	Lb-in	175.0
	Nm	19.75
	Amps	30.0
Torque Constant	Lb-in/A	5.80
	Nm/A	0.66
Resistance	Ohms	1.9
Inductance	mH	5.26
Maximum Speed	RPM	2100
Back EMF	V/Krpm	68
Armature Inertia	Lb-in-sec²	0.00900
	Kg-m²	0.001017

NOTE: All ratings based on a 40°C ambient temperature with the motor face mounted to a 12" x 12" x 1/2" aluminum heatsink.

GMR4940-38 PERFORMANCE DATA

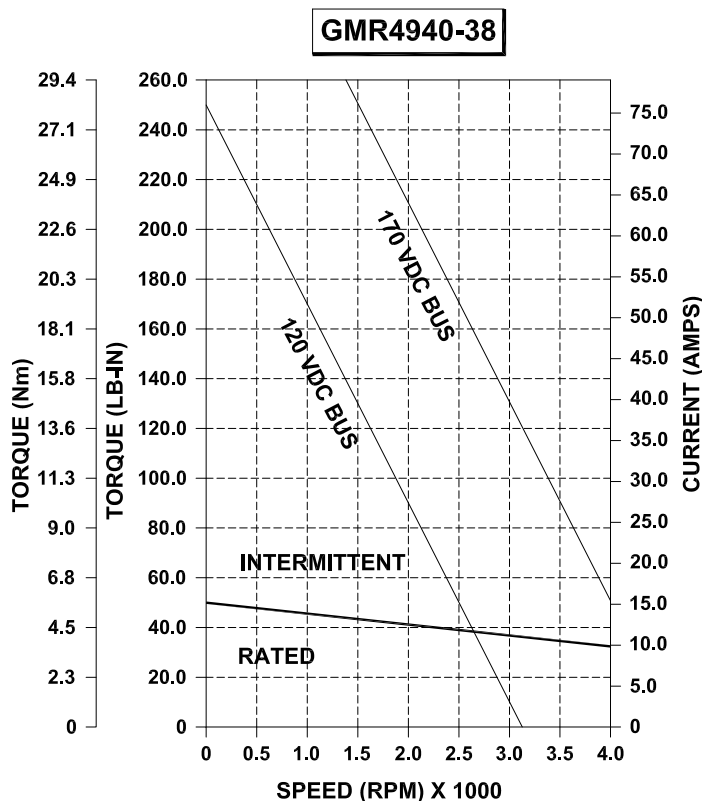

Power @ Max Speed	HP	3.02
	KW	2.253
Cont. Stall Rating	Lb-in	50
	Nm	5.65
	Amps	15.2
Peak Stall Rating	Lb-in	250.0
	Nm	28.25
	Amps	76.0
Torque Constant	Lb-in/A	3.28
	Nm/A	0.37
Resistance	Ohms	0.3
Inductance	mH	1.00
Maximum Speed	RPM	3800
Back EMF	V/Krpm	38
Armature Inertia	Lb-in-sec²	0.01500
	Kg-m²	0.001695

GMR4940-78 PERFORMANCE DATA

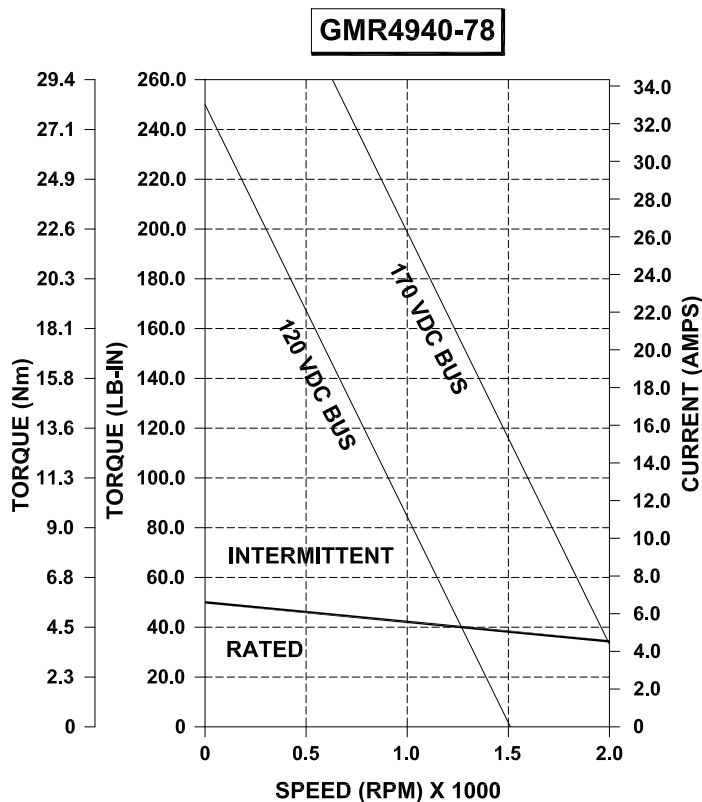

Power @ Max Speed	HP	1.34
	KW	0.999
Cont. Stall Rating	Lb-in	50
	Nm	5.65
	Amps	6.6
Peak Stall Rating	Lb-in	250.0
	Nm	28.25
	Amps	33.0
Torque Constant	Lb-in/A	6.60
	Nm/A	0.75
Resistance	Ohms	2.2
Inductance	mH	10.80
Maximum Speed	RPM	1700
Back EMF	V/Krpm	78
Armature Inertia	Lb-in-sec²	0.01600
	Kg-m²	0.001808

NOTE: All ratings based on a 40°C ambient temperature with the motor face mounted to a 12" x 12" x 1/2" aluminum heatsink.

GMR4950-35 PERFORMANCE DATA

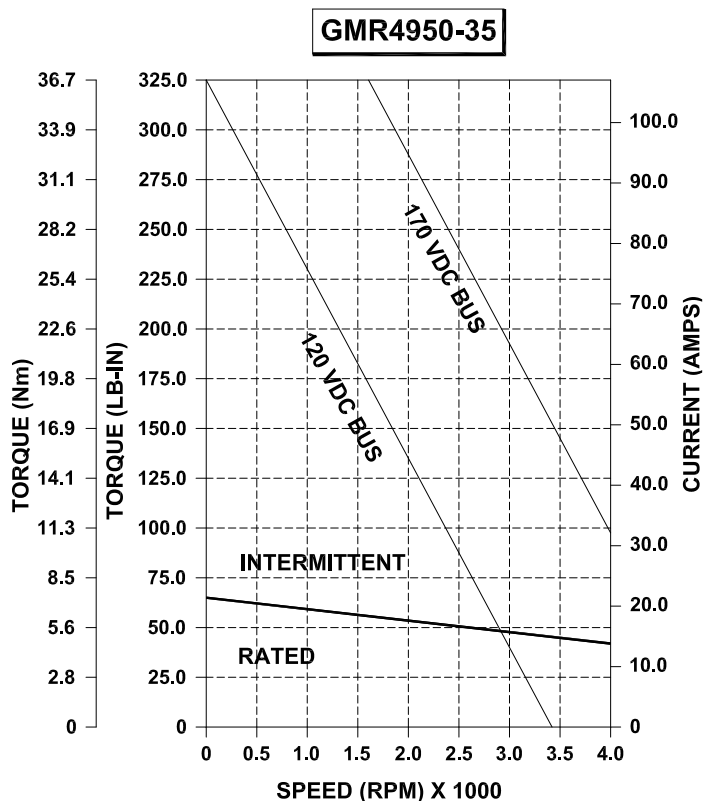

Power @ Max Speed	HP	4.13
	KW	3.081
Cont. Stall Rating	Lb-in	65
	Nm	7.34
	Amps	21.4
Peak Stall Rating	Lb-in	325.0
	Nm	36.70
	Amps	107.0
Torque Constant	Lb-in/A	3.04
	Nm/A	0.34
Resistance	Ohms	0.2
Inductance	mH	0.65
Maximum Speed	RPM	4000
Back EMF	V/Krpm	35
Armature Inertia	Lb-in-sec²	0.01600
	Kg-m²	0.001808

GMR4950-57 PERFORMANCE DATA

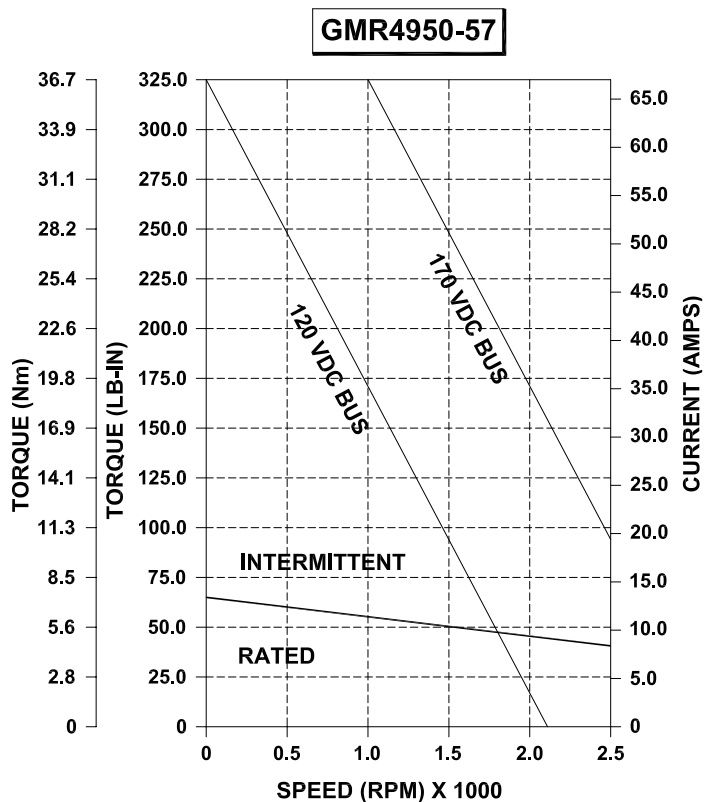

Power @ Max Speed	HP	2.58
	KW	1.924
Cont. Stall Rating	Lb-in	65
	Nm	7.34
	Amps	13.4
Peak Stall Rating	Lb-in	325.0
	Nm	36.70
	Amps	67.0
Torque Constant	Lb-in/A	4.87
	Nm/A	0.55
Resistance	Ohms	0.6
Inductance	mH	1.64
Maximum Speed	RPM	2500
Back EMF	V/Krpm	57
Armature Inertia	Lb-in-sec²	0.01600
	Kg-m²	0.001808

NOTE: All ratings based on a 40°C ambient temperature with the motor face mounted to a 12" x 12" x 1/2" aluminum heatsink.

GMR4900 SERIES MODEL NUMBERING

This section explains the model numbering system for Glentek's GMR4900 Series DC Brush Servo Motors. The model numbering system is designed so that you, our customer, will be able to quickly and accurately create the model number for the drive that best suits your requirements. Please complete the drive configuration code you require using the information on this page. After completing your model number, please contact a Glentek Sales Engineer to confirm that the model number you have created is correct.

GMR
49
20
-
38
-
0
2
8
0
0
5
0
0
-

- Frame Size** 49 = 4.9" Motor
- Stack Length** 20 = 2.0 inch stack
- Back EMF Constant** 38 = 38 V/Krpm
- Brake Option** 0 = No brake installed
- Tachometer Option** 2 = 7 VDC tachometer
- Encoder Option** 8 = 2500 PPR
- Brushless Resolver Option** 0 = No resolver installed
- Flange Type** 0 = Standard Round
- Lead Termination** 5 = Male MS connector, MS3102R-24-07P (16-pin style)
- Wiring Diagram** 0 = Glentek Standard
- Sealing Option** 0 = No shaft seal
- Factory Assigned Option** Leave blank

GMR

-

-

-

Frame Size	
49	4.9" Motor

Stack Length			
10	1.0" Stack	40	4.0" Stack
20	2.0" Stack	50	5.0" Stack

Back EMF Constant					
1.0" only	2.0" only	4.0" only	5.0" only		
26	26V/Krpm	38	38V/Krpm	38	38V/Krpm
35	35V/Krpm	57	57V/Krpm	78	78V/Krpm
37	37V/Krpm	68	68V/Krpm	78	78V/Krpm
For custom Back EMF, Please Contact Glentek					

Brake Option					
0	No brake installed	1	24 VDC Brake	2	Special

Tachometer Option					
0	No tachometer installed	2	7 VDC tachometer	4	Special
1	3 VDC tachometer	3	9.5 VDC tachometer	-	-

Encoder Option					
0	No encoder installed	4	1000 PPR	8	2500 PPR
2	500 PPR	6	2000 PPR	9	Special

Brushless Resolver Option			
0	No resolver installed	1	Brushless resolver
2	Special		

Flange Type					
0	Standard Round	3	M2	5	NEMA 56C
2	M1	4	M3	6	Special
		9			NEMA 42

Lead Termination			
0	Flying leads exiting through a rubber grommet	6	Liquid tight strain relief with flying leads
1	.5" NPT with flying leads	7	Terminal Box
2	.75" NPT with flying leads	8	Special
5	16-Pin, Male MS connector		

Wiring Diagram (MS conector lead termination only)			
0	Glentek Standard	1	Special

Sealing Option			
0	No shaft seal	1	Shaft Seal
2	Special		

Factory Assigned Option	
A numerical code will be assigned by Glentek to motors whoes specifications vary from the standard configuration	