

GLENTEK GMBF4300 BRUSHLESS SERVO MOTOR DIMENSIONS

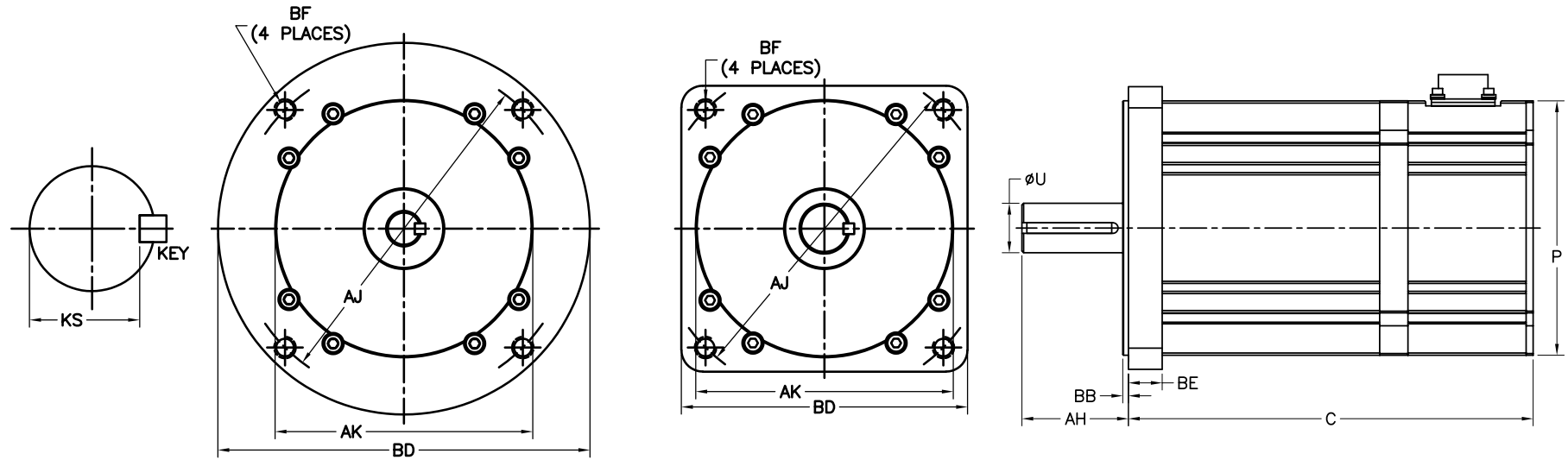

	Model Number	Kg (lbs.)	C (max)	P (max)	Shaft				Flange/Face				Mounting Hole		
					AH	U	KEY	KS	AK	BB	BD	BE	AJ	BF Ø	Tap
METRIC - mm (inches)	GMBF4320-XXX-M	4.1 (9.0)	201.7 (7.9)	108.0 (4.25)	50.00 (1.97)	19.00 (0.748)	M6 SQ. X 40	15.4 - 15.5	110.00 (4.331)	3.00 (0.12)	114.30 (4.50)	14.7 (0.58)	130.00 (5.118)	9.19 (0.362)	THRU
	GMBF4340-XXX-M	6.3 (13.9)	254.0 (10.0)	108.0 (4.25)	50.00 (1.97)	19.00 (0.748)	M6 SQ. X 40	15.4 - 15.5	110.00 (4.331)	3.00 (0.12)	114.30 (4.50)	14.7 (0.58)	130.00 (5.118)	9.19 (0.362)	THRU
	GMBF4360-XXX-M	8.5 (18.7)	306.3 (12.1)	108.0 (4.25)	50.00 (1.97)	19.00 (0.748)	M6 SQ. X 40	15.4 - 15.5	110.00 (4.331)	3.00 (0.12)	114.30 (4.50)	14.7 (0.58)	130.00 (5.118)	9.19 (0.362)	THRU
ENGLISH - inches (mm)	GMBF4320-XXX-E	9.0 (4.1)	7.94 (201.7)	4.25 (108.0)	1.88 (47.8)	0.6250 (15.88)	.188 SQ. X 1.50	.507 - .517	4.500 (114.30)	0.10 (2.54)	5.00 (127.0)	0.60 (15.24)	5.875 (149.23)		3/8-16 THRU
	GMBF4340-XXX-E	13.9 (6.3)	10.00 (254.0)	4.25 (108.0)	1.88 (47.8)	0.6250 (15.88)	.188 SQ. X 1.50	.507 - .517	4.500 (114.30)	0.10 (2.54)	5.00 (127.0)	0.60 (15.24)	5.875 (149.23)		3/8-16 THRU
	GMBF4360-XXX-E	18.7 (8.5)	12.06 (306.3)	4.25 (108.0)	1.88 (47.8)	0.6250 (15.88)	.188 SQ. X 1.50	.507 - .517	4.500 (114.30)	0.10 (2.54)	5.00 (127.0)	0.60 (15.24)	5.875 (149.23)		3/8-16 THRU
	NEMA 42				1.32 (33.5)	0.6250 (15.88)	.188 SQ. X 1.00	.507 - .517	2.188 (55.58)	0.10 (2.54)	4.50 (114.3)	0.60 (15.24)	4.950 (125.73)	0.300 (7.62)	THRU
	NEMA 56C				2.06 (52.3)	0.6250 (15.88)	.188 SQ. X 1.50	.507 - .517	4.500 (114.30)	0.12 (3.05)	6.50 (165.1)	0.61 (15.49)	5.875 (149.23)		3/8-16 THRU

NOTE: Metric and English motors are different models with differing dimensions.